

Deuterium retention in carbon dust and carbon–tungsten mixed dust prepared by deuterium arc discharge

H. Yoshida ^{a,*}, M. Taniguchi ^b, K. Yokoyama ^b, Y. Yamauchi ^a,
Y. Hirohata ^a, M. Akiba ^b, T. Hino ^a

^a Department of Nuclear Engineering, Hokkaido University, Kita-13, Nishi-8, Kita-ku, Sapporo 060-8628, Japan

^b Japan Atomic Energy Research Institute, Naka-machi, Ibaraki-ken 329-0193, Japan

Abstract

Deuterium retentions in carbon dust and carbon–tungsten mixed dust (C–W dust) were investigated to estimate the tritium inventory in fusion experimental reactors. Several types of carbon dust or C–W dust were prepared by D₂ arc discharge using carbon or carbon–tungsten electrodes, respectively. These were prepared by changing substrate temperatures with discharge pressure of 1.6 Pa. Deuterium retained in carbon dust was desorbed in the form of D₂, HD, CD₄ and C₂D₄. The peak temperature of the D₂ desorption rate was 1100 K. On the other hand, the deuterium retained in C–W dust was desorbed mainly in the form of D₂ and HD. The peak temperature of the D₂ desorption rate was 900 K. The deuterium concentrations in the atomic ratio, D/C, for carbon dust and C–W dust (C/W = 70/30) were reduced from 0.33 to 0.12 and from 0.7 to 0.07, respectively, when the substrate temperature increased from 300 to 850 K.

© 2004 Elsevier B.V. All rights reserved.

1. Introduction

Carbon fiber composite, tungsten and beryllium are employed for plasma facing materials of a fusion experimental reactor such as ITER [1]. These are eroded by plasmas, and then accumulated as co-deposited layers or dust in the vacuum vessel. Some kinds of dust were produced by peeling off the co-deposited layers. Tritium retention in the carbon dust co-deposited with fuel hydrogen has been predicted to be large [2,3], it is necessary to evaluate the fuel hydrogen retention in carbon dust, while the contribution of energetic tritium on the in-vessel tritium inventory will be small because of its small flux to the wall [3]. Control of the in-vessel tritium inventory is one of the critical issues for evaluation of the potential hazards of the fusion experimental reactor [2–6].

In many tokamak devices such as JET, TFTR, TEXTOR and DIII-D, carbon dust and co-deposited layers have been observed. The deuterium retention in this dust and co-deposited layers ranged from 10⁻⁴ to 0.95 in the atomic ratio, D/C, and it was reported one of the most important parameter determined D/C ratio was the wall temperature [3,7–10]. These data, however, may not be able to be extrapolated to fusion experimental reactors, since the wall condition has not been well characterized.

Carbon–tungsten mixed dust (C–W dust) has been also observed in tokamak devices such as TEXTOR and ASDEX-U [11,12]. However, the fuel hydrogen retention in the C–W dust has not been systematically examined.

In the present paper, carbon dust and C–W dust were prepared by D₂ arc discharge. Since the fuel hydrogen retention largely depends on the wall temperature, the substrate temperature was varied in the range from 300 to 850 K. The amount of retained deuterium was measured by thermal desorption spectroscopy (TDS). The C/W atomic ratio, surface morphology and crystal

* Corresponding author. Tel./fax: +81 11 706 6662.

E-mail address: yoshida@apollo.qe.eng.hokudai.ac.jp (H. Yoshida).

structure of the sample were also examined by AES, SEM and Raman spectroscopy.

2. Experiments

Carbon dust and C–W dust were prepared using a D_2 arc discharge (Fig. 1). The ultimate pressure was approximately 3×10^{-3} Pa. The deuterium gas was driven into the discharge chamber through a mass flow controller, and then D_2 arc discharge was turned on between the electrodes. For the preparation of carbon dust, two carbon electrodes were used. For the preparation of C–W dust, carbon and tungsten electrodes were used for anode and cathode, respectively. The discharge current and voltage were kept at 70 A and at about 17 V. These electrodes were sublimated during the arc discharge and then the carbon dust or the C–W dust was co-deposited with deuterium on a molybdenum substrate. These substrates were polished mechanically, and then degassed at 1100 K for 10 min.

In ITER, the gas pressure in the divertor region is estimated as approximately 1 Pa [13,14] and the temperature of the vacuum vessel is around 600 K [15,16]. The substrate temperature in these experiments was kept in the range 300–850 K by using a heater, and the average gas pressure of deuterium 1.6 Pa. The deposited rate of carbon dust and C–W dust were estimated from the weight gain of the Mo substrates after the discharge, the discharge time, and the atomic ratio, C/W and to be 10^{19} – 10^{20} atoms/m² s. In the arc discharge, the energy of atom is several eV, which is roughly comparable to the fuel hydrogen energy in the divertor region of ITER.

The amount of retained deuterium was measured by thermal desorption spectroscopy (TDS). In the TDS

analysis, the sample was heated by an infrared image furnace from room temperature to 1273 K. The ramp rate was 0.5 K/s and the holding time at 1273 K was 30 min. The atomic ratio, C/W, in the C–W dust was measured by Auger electron spectroscopy (AES). Surface morphology was examined by scanning electron microscope (SEM), and the crystal structure was examined by Raman spectroscopy.

3. Results and discussion

3.1. Structure of carbon dust and C–W dust

The film thickness of carbon dust and C–W dust ranged in 0.5–1.5 μm from the SEM observation. The depth profile of atomic composition of typical C–W dust is shown in Fig. 2. In this sample, the atomic ratio of carbon to tungsten, C/W, was measured as 74/26.

The crystal structures of carbon dust and C–W dust were examined by Raman spectroscopy. Raman spectra of carbon and C–W dust are shown in Fig. 3. The atomic ratio, C/W, in this C–W dust was approximately 70/30. The spectrum of carbon dust prepared at 300 K had a single peak at around 1520 cm^{-1} , which is a typical peak for hydrogenated amorphous carbon [17]. As the substrate temperature was increased, two peaks appeared at about 1580 cm^{-1} (G-band) and 1360 cm^{-1} (D-band). The G-band attributes graphite crystal structure and D-band attributes a defect structure of graphite [18]. Thus, the crystal structure of carbon dust became graphite-like with increase of substrate temperature. In the case of C–W dust, a similar tendency was observed, but the peak of D-band was relatively large compared with the case of carbon dust. Then, the C–W dust is closer to amorphous state than the carbon dust.

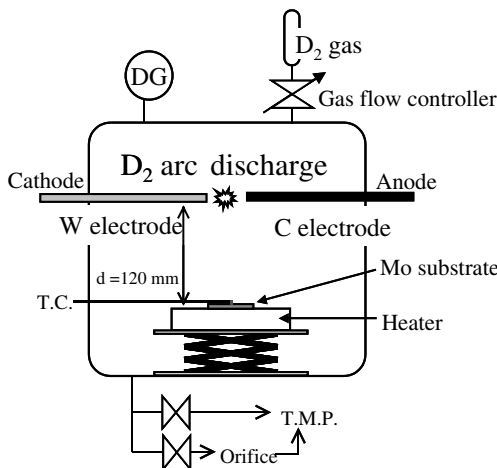

Fig. 1. D_2 arc discharge apparatus. This figure shows the case of C–W dust preparation.

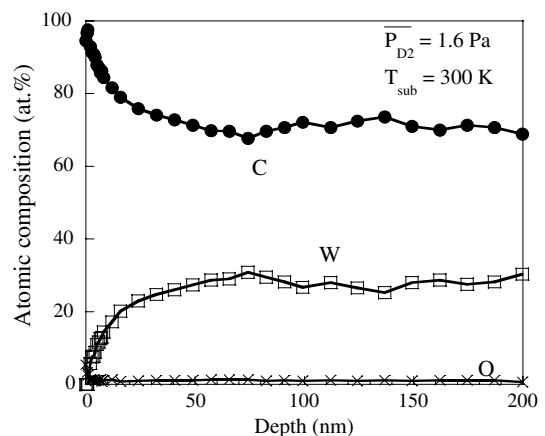

Fig. 2. Depth profile of atomic composition of C–W dust, prepared at 1.6 Pa and 300 K.

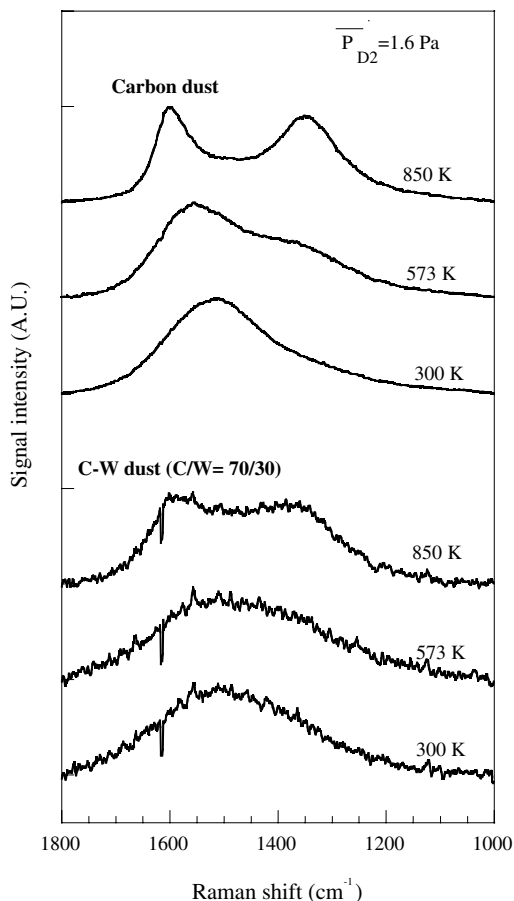

Fig. 3. Raman spectra observed from carbon dust and C–W dust.

3.2. Deuterium retention in carbon dust and C–W dust

TDS spectra of carbon dust and C–W dust (C/W atomic ratio = 74/26) prepared at 300 K are shown in Fig. 4. The deuterium retained in carbon dust was desorbed in the form of D_2 , HD, CD_4 , and C_2D_4 . The D_2 desorption rate had a single peak at around 1100 K. From C–W dust, the retained deuterium was desorbed mainly in the form of D_2 and HD. The desorption of hydrocarbon from C–W dust was one order of magnitude smaller than that from carbon dust. The peak temperature of D_2 desorption rate was approximately 900 K, which is 200 K lower than for carbon dust.

The desorption spectrum of carbon dust was similar to that of graphite after deuterium ion irradiation [19]. Thus, it is presumed that deuterium is in the form of C–D bonding in carbon dust. In the C–W dust, the single desorption peak was observed, which differs from the case of tungsten carbide after deuterium ion irradiation [21,20]. In tungsten carbide, two peaks appeared at 420 K and 900 K. The desorption at lower temperature is

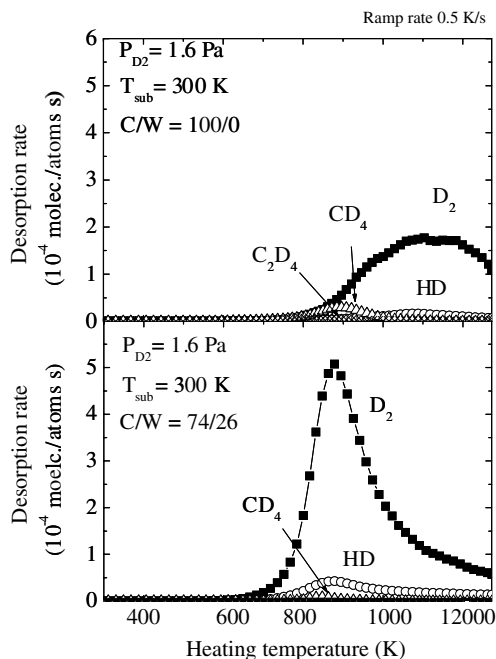

Fig. 4. TDS spectra for carbon dust and C–W dust, prepared at 1.6 Pa and 300 K. The desorption rate was normalized by host atoms (C or C + W).

due to detrapping of deuterium from tungsten, and that at higher temperature due to detrapping of deuterium from carbon. In the present C–W dust, the desorption of deuterium at around 900 K can be regarded as the detrapping of deuterium from carbon. Thus, it is believed that the deuterium in C–W dust is trapped mainly with carbon.

C–W dust had a peak desorption temperature lower than that of carbon dust. This difference is due to the high recombination probability for deuterium atoms in the C–W dust, since the diffusion rate of deuterium atoms in tungsten is several orders of magnitude larger than that in carbon in the present experimental condition [6]. The low temperature shift of D_2 desorption from carbon was also observed in WC layer compared with the case of graphite [22].

The amount of retained deuterium was obtained by integrating the desorption rate with heating time. The number of C and W atoms were estimated from the weight of the dust and atomic composition obtained by AES analysis. The deuterium concentration in atomic ratio, D/C or D/(C+W), was obtained by these parameters. For the C–W dust, the atomic ratio of D/C was also obtained since most of deuterium is trapped with carbon. In Table 1, the atomic ratios of D/C and D/(C+W) for the dust are shown. The atomic ratio of D/C in carbon dust was 0.33, which is roughly the same as the case of deuterium ion irradiation for graphite,

Table 1
The deuterium concentration in the carbon dust and C–W dust

C/W atomic ratio	D/(C + W)	D/C ^a
100/0 (Carbon dust)	0.33	0.33
94/6	0.31	0.33
78/22	0.57	0.73
74/26	0.50	0.68

^aThe atomic ratio, D/C, in C–W dust was estimated by assuming all of retained deuterium atoms were trapped in only carbon atoms.

D/C = 0.4 when the substrate temperature was 300 K [3,6]. The deuterium concentration, D/C, increased with increase of the tungsten concentration. Since the structure of carbon in C–W dust becomes closer to amorphous state as the tungsten concentration increases, the number of trapping site of C for D, such as defects, must become larger. This is one of reasons why the concentration of retained deuterium in C–W dust was higher than that in carbon dust.

The dependence of deuterium concentration in carbon dust and in C–W dust on substrate temperature is shown in Fig. 5. Here, the atomic ratio of C/W in C–W dust was approximately 70/30. The amount of retained deuterium decreased with increase of the substrate temperature. At the temperature range below 700 K, the deuterium concentration in C–W dust was higher than that in carbon dust. At higher temperature, the deuterium concentration in C–W dust was comparable with that in carbon dust. In the case of ITER, the wall temperature may be higher than 700 K and the corresponding concentration in atomic ratio is lower than 0.5. In the divertor region, the wall temperature may be higher than 1000 K. In this case, the concentration of D/C will be less than 0.1. These data may be useful for estimation of the in-vessel tritium inventory.

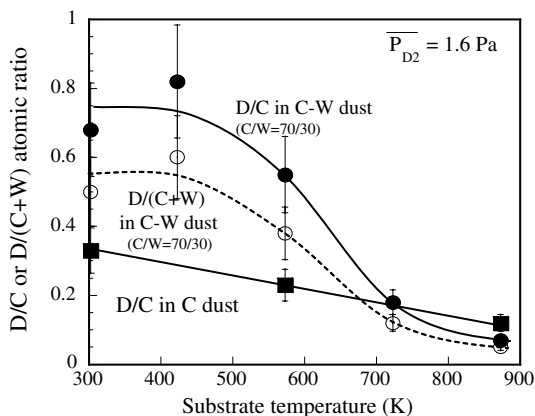

Fig. 5. The dependence of deuterium concentration of carbon dust and C–W dust on the substrate temperature.

4. Conclusions

Carbon dust and C–W dust samples were prepared by D₂ arc discharge. In the preparation, the substrate temperature was varied from 300 to 850 K and the average deuterium gas pressure was kept around 1.6 Pa.

Deuterium retained in carbon dust was desorbed in the form of D₂, HD, CD₄ and C₂D₄. The peak temperature for D₂ desorption rate was 1100 K. For C–W dust, the retained deuterium was desorbed in the form of D₂ and HD. The peak temperature of D₂ desorption rate was 900 K, which is lower than that of carbon dust. The desorption peak of D₂ in C–W dust indicates that the deuterium was trapped mainly by carbon. In C–W dust, the deuterium concentration increased with increase of tungsten concentration when the substrate temperature was room temperature. The deuterium concentrations in the atomic ratio, D/C, for carbon dust and C–W dust decreased with the increase of the substrate temperature.

In ITER, the gas pressure is estimated as approximately 1 Pa, and the wall temperature 600 K. Extrapolating the present result to the ITER condition, the deuterium concentration in the atomic ratio, D/C, in carbon dust was estimated to be 0.2. In C–W dust, the atomic ratio, D/C, is higher than that of carbon dust. In order to reduce the fuel hydrogen inventory of carbon dust or C–W dust, one promising method is to increase the wall temperature.

Acknowledgements

The authors are grateful to Dr Y. Sasaki, Hokkaido University for the help in Raman spectroscopy measurement. The authors thank the members of the Blanket Engineering Laboratory in JAERI for their valuable discussions and comments.

References

- [1] G. Janeschitz et al., *Fusion Eng. Des.* 39&40 (1998) 173.
- [2] R.A. Causey et al., *Fusion Eng. Des.* 61&62 (2002) 525.
- [3] T. Tanabe et al., *J. Nucl. Mater.* 313–316 (2003) 478.
- [4] T. Hino, *Fusion Eng. Des.* 39&40 (1998) 439.
- [5] G. Federici et al., *J. Nucl. Mater.* 266–269 (1999) 14.
- [6] R.A. Causey, *J. Nucl. Mater.* 300 (2002) 91.
- [7] M. Mayer et al., *J. Nucl. Mater.* 290–293 (2001) 381.
- [8] D.G. Whyte et al., *Nucl. Fusion* 39 (8) (1999) 1025.
- [9] V. Rohde et al., *J. Nucl. Mater.* 290–293 (2001) 317.
- [10] A.T. Peacock et al., *J. Nucl. Mater.* 266–269 (1999) 423.
- [11] D. Hildebrandt et al., *J. Nucl. Mater.* 290–293 (2001) 89.
- [12] D. Hildebrandt et al., *J. Nucl. Mater.* 266–269 (1999) 532.
- [13] A. Mack et al., *Fusion Eng. Des.* 61&62 (2002) 611.
- [14] H.D. Pacher et al., *J. Nucl. Mater.* 266–269 (1999) 1172.
- [15] J.N. Brooks et al., *J. Nucl. Mater.* 266–269 (1999) 58.
- [16] G. Janeschitz et al., *Fusion Eng. Des.* 49&50 (2000) 107.

- [17] H. Minagawa, T. Hino, T. Yamashina, M. Watanabe, N. Noda, T. Mizuuchi, O. Motojima, A. Iiyoshi, K. Uo, J. Nucl. Mater. 162–164 (1989) 776.
- [18] K. Niwase, T. Tanabe, Mater. Trans. JIM 34 (11) (1993) 1111.
- [19] Y. Yamauchi, Y. Hirohata, T. Hino, Fusion Eng. Des. 39&40 (1998) 427.
- [20] T. Hino, F. Hirano, Y. Yamauchi, Y. Hirohata, Fusion Eng. Des. 49&50 (2000) 213.
- [21] W. Wang, V.Kh. Alimov, B.M.U. Scherzer, J. Roth, J. Nucl. Mater. 241–243 (1997) 1087.
- [22] T. Horikawa, K. Morita, B. Tsuchiya, J. Nucl. Mater. 290–293 (2001) 428.